

F114 and F115 Ceiling Surface Mounted Media Air Cleaners

PRODUCT DATA



FEATURES

- High Efficiency Particulate AIR (HEPA) filter models are 99.97% efficient and the D.O.P. particle filter models are 95% efficient at 0.3 micron particles. Both models are more efficient on particles smaller and larger.
- F114 two-speed, direct-drive, forward curve, motor/blower models deliver up to 325 cfm (550 m3/hr).
- F115 single speed models deliver up to 600 cfm (1020 m3/hr) .
- Select models include CPZ™ disposable canisters for odor control.
- Light colored covers complement the ceiling finish.
- Available in 120 Vac, 60 Hz or 220-240 Vac, 50/60 Hz models.

• READ AND SAVE THESE INSTRUCTIONS

GENERAL

The F114 and F115 Ceiling Surface Mounted Media Air Cleaners use direct-drive, forward curve, blower/motors with 95% D.O.P. particle or HEPA filters to remove airborne contaminants. The air cleaners are designed for use in restaurants, conference rooms, lounges and offices where overhead air cleaning is required. They provide their own air circulation, so the air cleaners can be used in any situation that requires the reduction of contamination from an enclosed area.

Contents

| | |
|---------------------------------|----|
| General | 1 |
| Features | 1 |
| Specifications | 2 |
| Ordering Information | 2 |
| Planning the Installation | 3 |
| Installation | 4 |
| Operation | 5 |
| Service | 5 |
| Parts List | 6 |
| Warranty | 10 |

F114 AND F115 CEILING SURFACE MOUNTED MEDIA AIR CLEANERS

SPECIFICATIONS

IMPORTANT

The specifications given in this publication do not include normal manufacturing tolerances. Therefore, this unit may not exactly match the listed specifications. This product is tested and calibrated under closely controlled conditions, and some minor differences in performance can be expected if those conditions are changed.

Models:

Refer to Table 1 for model descriptions.

Color:

F114: white cabinet and cover.
F115: white cabinet and cover.

Blower/Motor:

F114: two-speed, direct-drive, forward curve.
F115: single-speed, direct-drive, forward curve.

Table 1. F114 and F115 Description.

| Model | Voltage | Efficiency | | Air Volume in cfm (m3/hr) |
|-------|-----------------------------------|---|--|------------------------------------|
| | | Particulates at 0.3 Micron (D.O.P. Test) | Approximate CPZ™ components in pounds | |
| F114A | 120 Vac, 60 Hz, 1PHS, 3.6A | 99.97% HEPA | N/A | HI = 325 (550); LOW = 180 (306) |
| | 220-240 Vac, 60 Hz, 1PHS, 1.7A | 99.97% HEPA | NA | HI = 325 (550) LOW = 180 (306) |
| F114C | 120 Vac, 60 Hz, 1PHS, 3.6A | 95% | 7 | HI = 350 (595); LOW = 200 (340) |
| | 220-240 Vac, 50/60 Hz, 1PHS, 1.7A | 95% | 7 | HI = 320 (544); LOW = 165 (280) |
| F115A | 120 Vac, 60 Hz, 1PHS, 7.2A | 99.97% HEPA | N/A | 600 (1020) |
| | 220/240 Vac, 60 Hz, 1PHS, 8.6A | 99.97% HEPA | N/A | 600 (1020) |
| F115C | 120 Vac, 60 Hz, 1PHS, 7.2A | 95% | 12 | 600 (1020) |
| | 220/240 Vac, 50/60 Hz, 1PHS, 3.6A | 95% | 12 | 550 to 600 (935 to 1020) |

^aNot applicable.

ORDERING INFORMATION

If you have additional questions, need further information, or would like to comment on our products or services, please write or phone:

1. **Your local Honeywell Commercial Air Products Distributor.**

2. **Air-Pure Systems**

16873 Fish Point Rd. SE
Prior Lake, MN 55372-1714
Phone: (800) 998-1919
Fax: (800) 221-3248
www.cleanairfacility.com

F114 AND F115 CEILING SURFACE MOUNTED MEDIA AIR CLEANERS

Dimensions:

See Fig. 1 and 2 for dimensions.

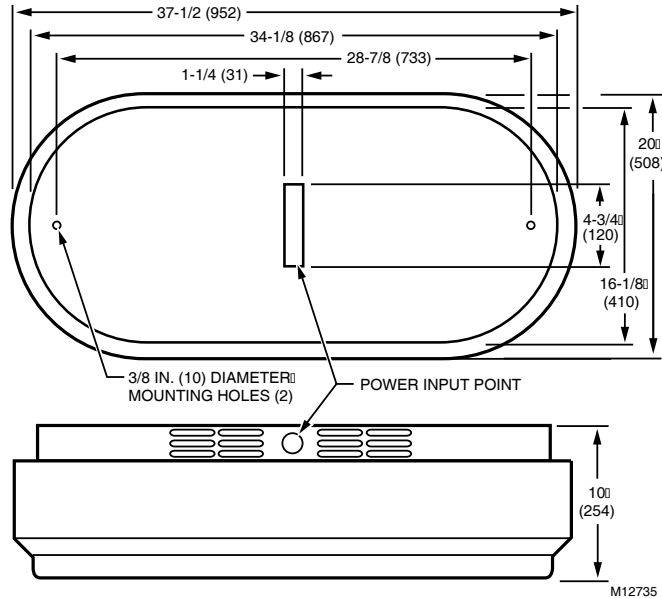

Fig. 1. Approximate dimensions of F114 in in. (mm).

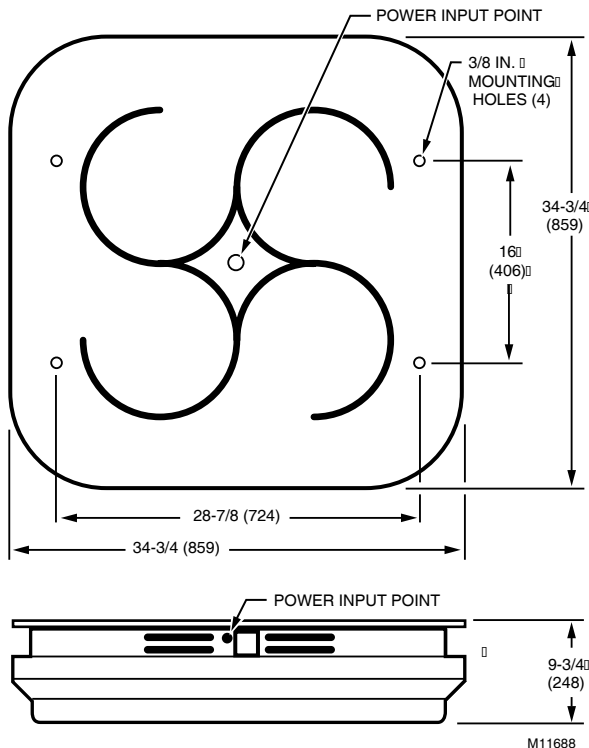

Fig. 2. Approximate dimensions of F115 in in. (mm).

Installation Weight:

F114: approximately 40 lbs (18 kg).

F115: approximately 80 lbs (36 kg).

Controls:

F114: two speed On/Off switch.

F115: direct wired (optional remote mounted On/Off switch).

Sound Level at 3.3 ft (1m):

F114: 59 dBA on High speed, 55 dBA on Low speed.

F115: 52 to 56 dBA.

Replacement Parts and Accessories:

See Parts List on page 8.

PLANNING THE INSTALLATION

⚠ WARNING

Electrical Shock Hazard.

Power source can cause personal injury.

- Do not damage electrical wiring or hidden utilities when cutting or drilling into the wall or ceiling.
- Do not install where the media air cleaner can be reached from a tub or shower.
- Always turn off the power at the service panel. Lock the panel to prevent the power from being switched on accidentally when servicing or cleaning the media air cleaner.

Choose Location

The air cleaner is mounted horizontally and can be used in almost any air cleaning application. For the most efficient operation, centrally locate the air cleaner to the area to be cleaned.

For the best air patterns, avoid discharging the air directly at an obstruction such as a ceiling beam, decorative cornice or pillar. The discharge air pattern has a range of 20 to 25 ft (6 to 7.5m) at full speed.

IMPORTANT

Do not install at heights greater than 16 ft (4.8m).

When multiple air cleaners are needed for a large area, divide the space into equal areas and centrally mount the air cleaners. See Fig. 3.

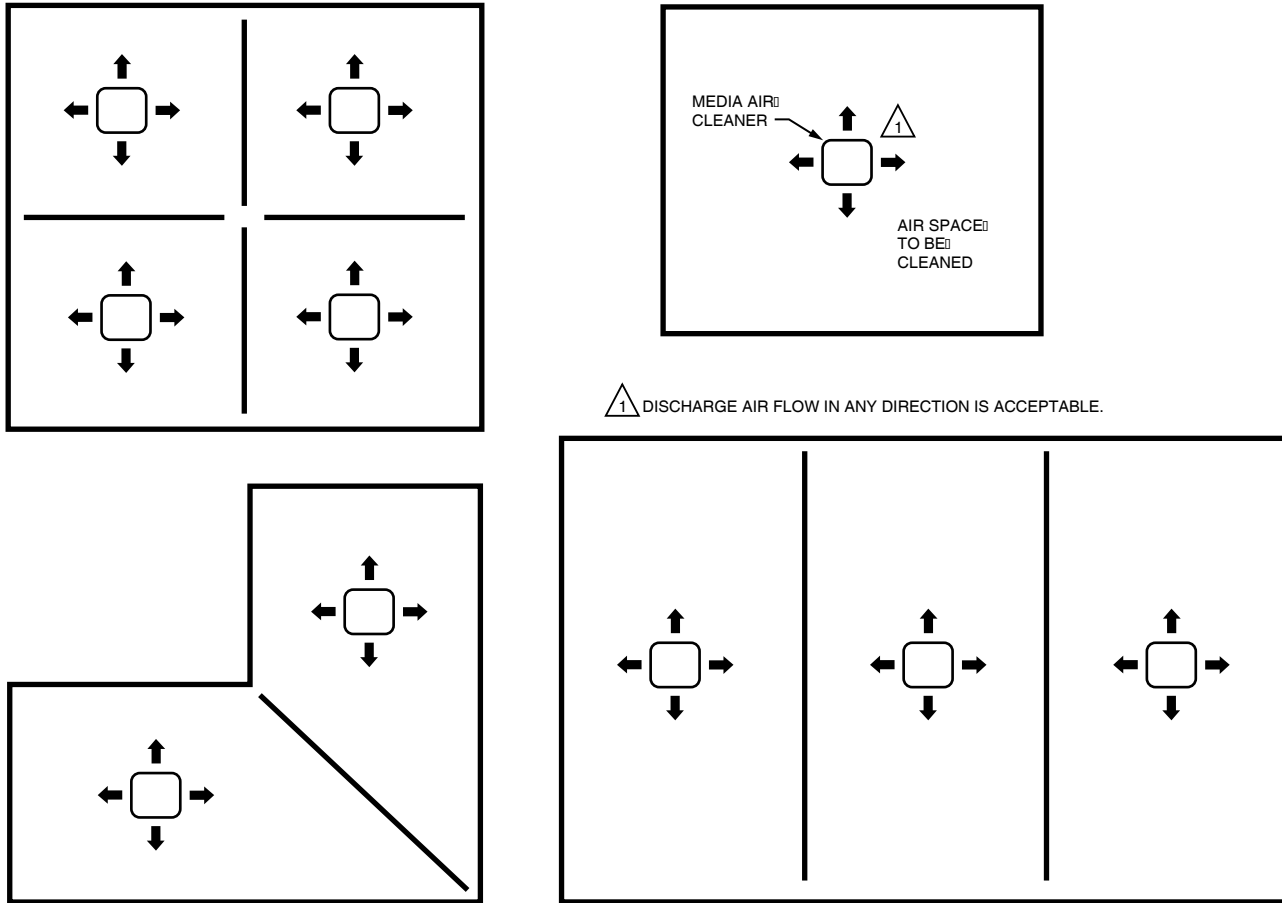

1 DISCHARGE AIR FLOW IN ANY DIRECTION IS ACCEPTABLE.

M11694

Fig. 3. Choose location for air cleaners.

IMPORTANT

When selecting a location, make sure the air cleaner is secured to ceiling load-bearing supports or joists. If installing on a T-grid drop ceiling, secure the air cleaner to the true ceiling.

INSTALLATION

When Installing this Product...

1. Read these instructions carefully. Failure to follow them could damage the product or cause a hazardous condition.
2. Check the ratings given in the instructions and on the product to make sure the product is suitable for your application.
3. Installer must be a trained, experienced service technician.
4. After installation is complete, check out product operation as provided in these instructions.



CAUTION

Electrical Shock Hazard. Power source can shock.

- Do not connect the power source until after the air cleaner is mounted. This will prevent electrical shock or equipment damage.
- Be sure to turn off the air cleaner before servicing it.
- If the air cleaner must be turned on for an electrical check, be extremely cautious.
- Be cautious when working near the moving parts of the air cleaner.



CAUTION

Eye Exposure.

Harmful dust can obstruct or injure unshielded eyes.

A CPZ™ module usually releases dust when it is handled.

Always wear safety glasses when installing or removing CPZ™ canisters.

F114 AND F115 CEILING SURFACE MOUNTED MEDIA AIR CLEANERS

IMPORTANT

When installing the air cleaner, be sure to follow all local codes and accepted practices.

1. Decide if the air cleaner wire connections will be from the top or the side. Make the necessary wiring provisions at the ceiling.
2. Grasp the air cleaner cover edge near the plenum and remove the cover from the support brackets. Set it aside.
3. Loosen and remove the filter securing nuts, holding plates and filters. Set them aside.
4. Insert fastening hardware (lag bolts, eye bolts or threaded rod) through the 3/8 in. (10 mm) mounting holes in the filter/motor bases. See Fig. 1 or 2.
5. Secure the air cleaner to the ceiling load bearing supports or joists. If installing on a T-grid drop ceiling, secure the air cleaner to the true ceiling.
6. Fasten the plenum assembly snugly against the ceiling.

IMPORTANT

Do not over-tighten the plenum fasteners which can collapse or break the plastic base/plenum.

7. Connect the power. See Fig. 4 and 5.

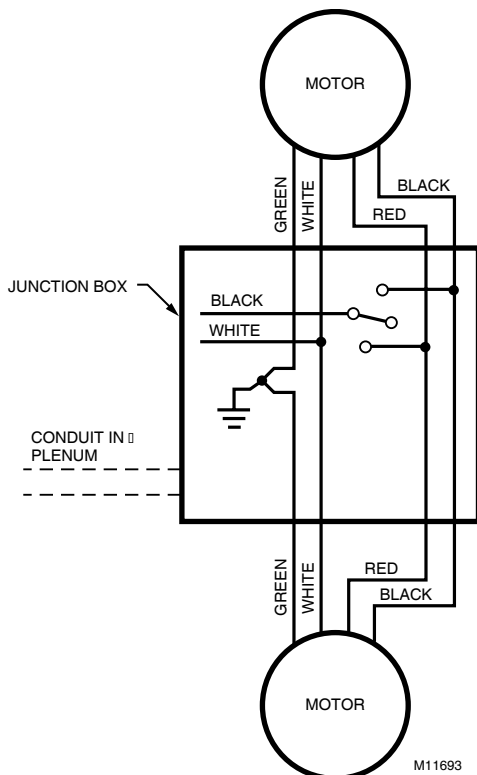

Fig. 4. F114 Media Air Cleaner (120, 60 Hz) typical wiring diagram.

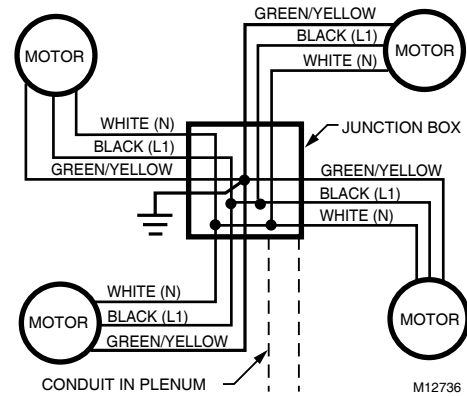

Fig. 5. F115 Media Air Cleaner (120, 60 Hz) typical wiring diagram.

IMPORTANT

Make sure the air cleaner is grounded for proper operation and safety.

8. Turn on the power and check that the blowers are operating freely.
9. Position the filter cartridges on the filter base.
10. Insert the CPZ™ cartridge with the cartridge base notches against the motor towers.
11. Attach the filter cover plates.
12. Replace the air cleaner cover.

OPERATION

The F114 and F115 Ceiling Surface Mounted Media Air Cleaners provide their own air circulation. When the air cleaner is powered, the blower/motor draws the contaminated air into the air cleaner. Particles that are too small to be caught in the prefilter are removed by the particle or HEPA filter. The cleaned air is then returned to the building space.

In areas with ceilings up to 10 feet high, the F114 models can effectively clean an area of 200 to 600 sq ft (18 to 54 sq m). The F115 models can clean a 600 to 1200 sq ft (54 to 108 sq m) area.

SERVICE

The air cleaner removes a variety of particulate contaminants from the air. In the process of cleaning the air, the air cleaner filters become dirty.

To maintain a high standard of reliability and efficiency, it is necessary to periodically service the air cleaner. The filter life is determined by the quantity and type of contaminants present and the frequency of air cleaner use. In relatively clean spaces, the filter life can extend as long as 30 months. In areas that are very smoky and dusty, filters need to be replaced sooner. The frequency of servicing can only be established after a period of use.

NOTE: Some Full-Service Distributors provide regular servicing to commercial establishments.

F114 AND F115 CEILING SURFACE MOUNTED MEDIA AIR CLEANERS

CAUTION

**Electrical Shock Hazard.
Power source can shock.**

- Turn off the power to the air cleaner when cleaning or servicing.
- Stand on a stable platform when working with the air cleaner.

CAUTION

**Eye Exposure.
Harmful dust can obstruct or injure unshielded eyes.**

A CPZ™ module usually releases dust when it is handled.

Always wear safety glasses when installing or removing CPZ™ canisters.

1. Grasp the edge of the air cleaner cover near the plenum and remove the cover from the support brackets. Set it aside.
2. Remove the prefilters.
3. Check the prefilters and replace them if they are fully coated with dust and lint (approximately every 1 to 3 months).
4. Replace the CPZ™ cartridge when a continuous noticeable odor is emitted from the air cleaner (approximately every 4 to 12 months).
5. Replace the primary filter when there is a noticeable loss of air volume circulation (approximately every 10 to 24 months).
6. Reassemble the air cleaner and turn the power on.

PARTS LIST

Refer to Table 2 or 3 and Fig. 6 or 7 for a parts list and an exploded view of the parts.

Table 2. F114 Ceiling Surface Mounted Media Air Cleaner Parts List.

| Fig. Reference No. | Description | Pack Qty | Order Number | Reference No. |
|--------------------|--|----------|--------------|---------------|
| 1 | Inspection plate cover | 1 | 32000243 | 901402 |
| 2 | Three-position switch | 1 | 32000244 | 901533 |
| 3 | Blower wheel | 1 | 32000245 | 902515A |
| 4 | 120V, 60 Hz, 2-speed motor | 1 | 32000250 | 906079 |
| | 220-240V, 50/60 Hz motor | 1 | -- | -- |
| 5 | Mid-plate | 1 | 32000241 | 900204 |
| 6 | Prefilter | 2 | 32000223 | 32002 |
| 7 | HEPA filter (requires 2) | 1 | 32000206 | 21500 |
| | D.O.P. Particle filter (requires 2) | 1 | 32000217 | 28710 |
| 8 | Disposable CPZ cartridge (requires 2) | 1 | 32000232 | 36210 |
| 9 | Filter holding plate with stud and nut | 1 | 32000247 | 905037 |
| 10 | Lid/Cover | 1 | 32000375 | -- |
| 11 | Grill Cover | 1 | 32000251 | 911352 |
| 12 | Knob | 1 | 32000242 | 901400 |

F114 AND F115 CEILING SURFACE MOUNTED MEDIA AIR CLEANERS

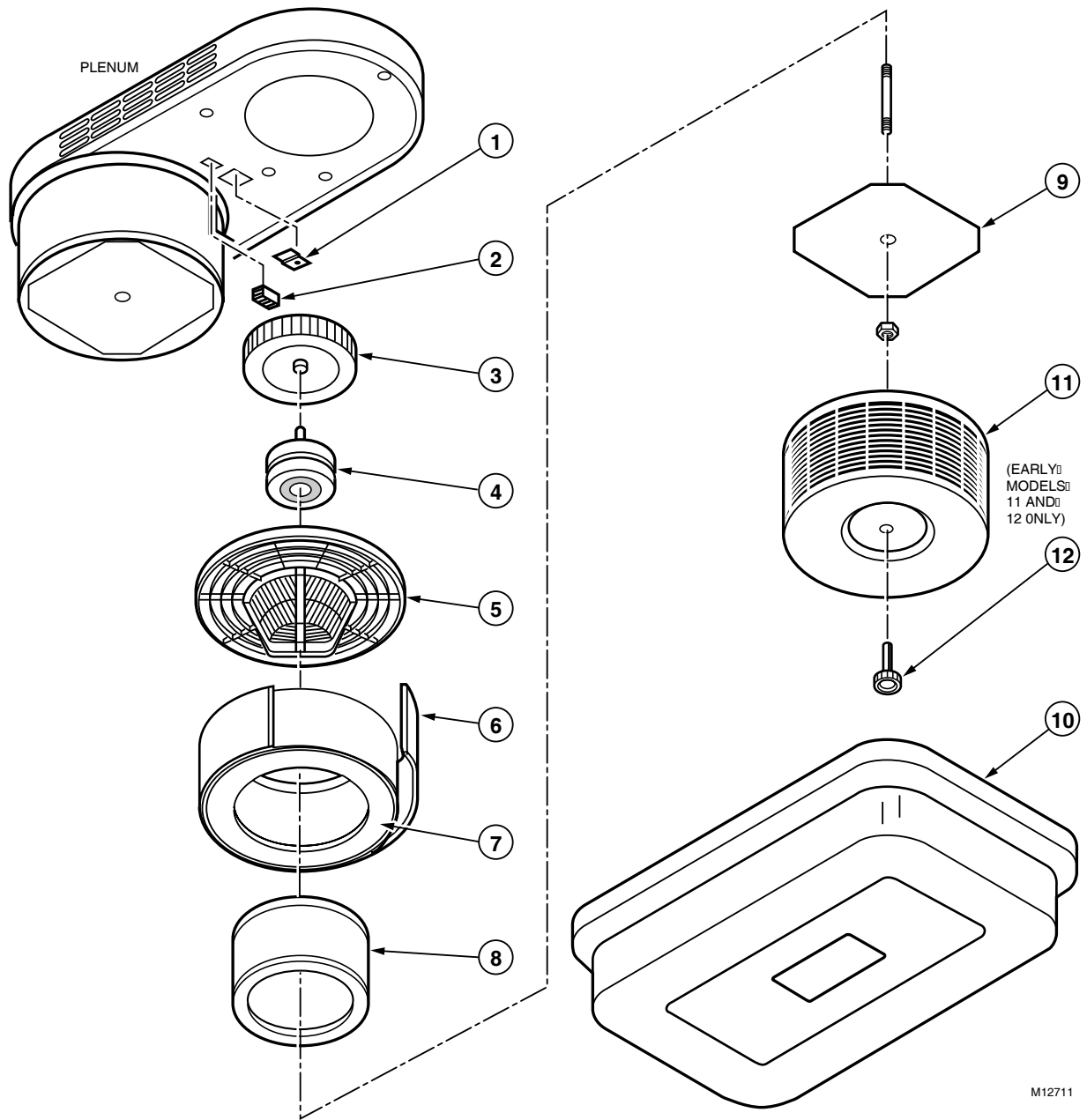

Fig. 6. Exploded view of F114 Ceiling Surface Mounted Media Air Cleaner components.

M12711

F114 AND F115 CEILING SURFACE MOUNTED MEDIA AIR CLEANERS

Table 3. F115 Ceiling Surface Mounted Media Air Cleaner Parts List.

| Fig. Reference No. | Description | Pack Qty | Order Number | Reference No. |
|--------------------|--|----------|--------------|---------------|
| 1 | Blower Wheel | 1 | 32000245 | 902515A |
| 2 | 120V, 60 Hz | 1 | 32000249 | 905067 |
| | 220-240V, 50/60 Hz motor | 1 | 32001839 | -- |
| 3 | Mid-plate | 1 | 32000241 | 900204 |
| 4 | Prefilter (1 box) | 4 | 32000229 | 36015 |
| | 10 boxes | 40 | 32000230 | 36016 |
| 5 | HEPA filter (requires 4) | 1 | 32000206 | 21500 |
| | D.O.P. Particle filter (requires 4) | 1 | 32000217 | 28710 |
| 6 | Disposable CPZ canister (requires 4) | 1 | 32000232 | 36210 |
| 7 | Filter holding plate with stud and nut | 1 | 32000247 | 905037 |
| 8 | Lid/cover | 1 | 32000246 | 905001 |

F114 AND F115 CEILING SURFACE MOUNTED MEDIA AIR CLEANERS

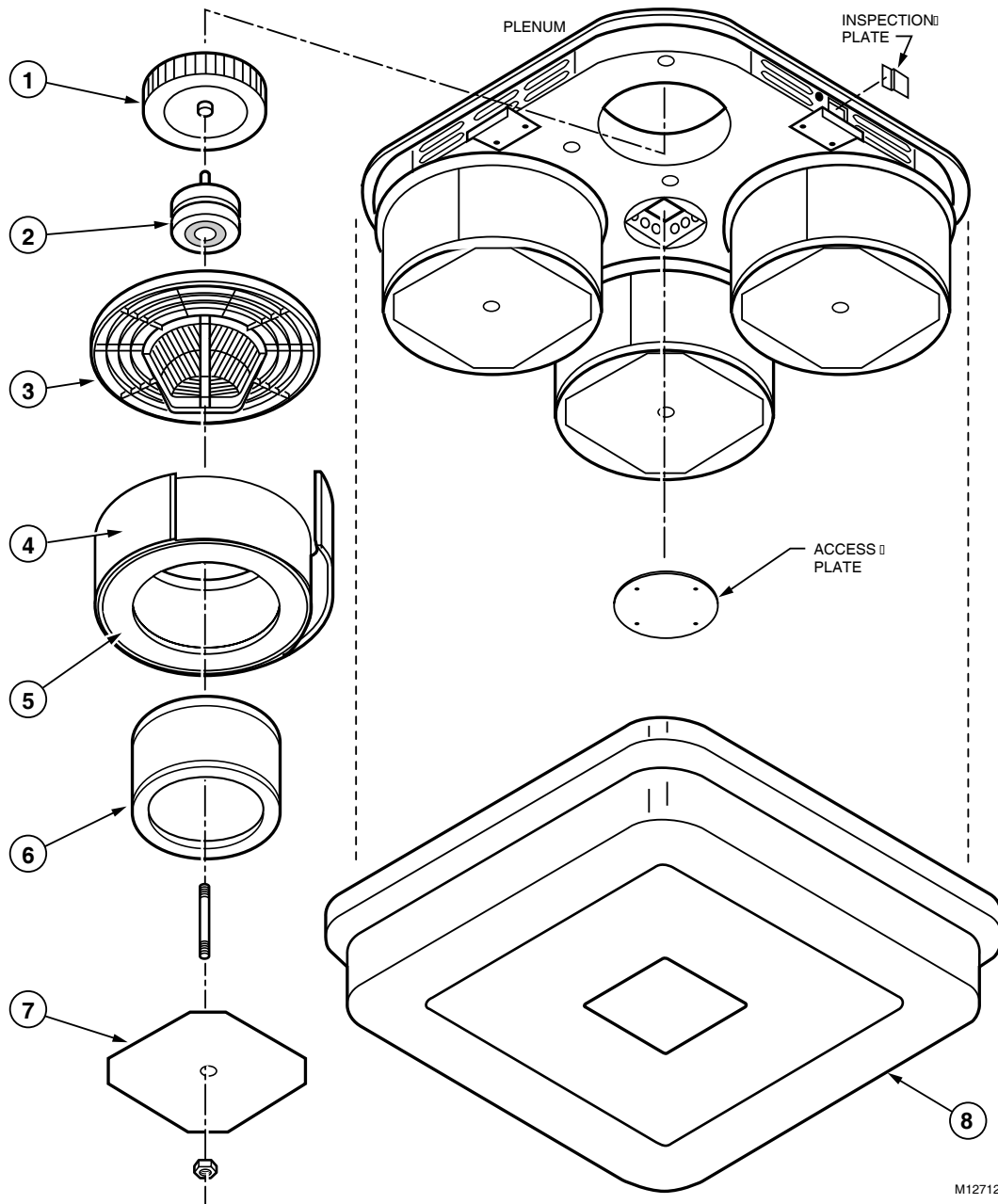

Fig. 7. Exploded view of F115 Ceiling Surface Mounted Media Air Cleaner components.

NOTES

NOTES

F114 AND F115 CEILING SURFACE MOUNTED MEDIA AIR CLEANERS

LIMITED TWO-YEAR WARRANTY

Air-Pure Systems warrants its air cleaner products to be free from defects in workmanship or materials under normal use and service, for a period of two (2) years from the date of purchase by the original end-user. If at anytime during the warranty period the product is defective or malfunctions, Air-Pure Systems, through the distributor or dealer, from which the product was purchased, or through an authorized warranty repair station, shall at Air-Pure Systems option, replace or repair the defective product or component.

This warranty does not cover removal or installation costs. This warranty shall not apply if it is shown that the defect or malfunction was caused by damage which occurred during handling or shipment, improper electrical connections, improper use of the product or abuse.

Air-Pure Systems sole responsibility shall be to repair or replace the product within the terms stated above. **AIR-PURE SYSTEMS SHALL NOT BE LIABLE FOR ANY LOSS OR DAMAGE OF ANY KIND, INCLUDING ANY INCIDENTAL OR CONSEQUENTIAL DAMAGES RESULTING, DIRECTLY OR INDIRECTLY, FROM ANY BREACH OF WARRANTY, EXPRESS OR IMPLIED, OR ANY OTHER FAILURE OF THIS PRODUCT.** (Some states do not allow the exclusion or limitation of incidental or consequential damages, so this limitation may not apply to you.). **THE WARRANTIES SET FORTH HEREIN ARE EXCLUSIVE AND AIR-PURE SYSTEMS EXPRESSLY DISCLAIMS ALL OTHER WARRANTIES, WHETHER WRITTEN OR ORAL, IMPLIED OR STATUTORY, INCLUDING BUT NOT LIMITED TO ANY WARRANTIES OR MERCHANTABILITY, WORKMANSHIP, OR FITNESS FOR A PARTICULAR USE.**

This warranty gives you specific legal rights and you may have other rights which vary from state to state.

How to make a warranty claim or have questions answered:

Should you have a warranty claim or questions about the warranty policy, contact the distributor or dealer from which you purchased the product or the authorized warranty repair stations nearest your location.

NOTE: Do not return any products or parts to the factory without a factory issued "Return Warranty Good Label" issued by Air-Pure Systems.

In the event you or other persons, have any questions concerning the use and care of this product of this warranty please call or write the factory.

Air-Pure Systems

16873 Fish Point Rd. SE
Prior Lake, MN 55372-1714
Phone: (800) 998-1919
Fax : (800) 221-3248

Air-Pure Systems

16873 Fish Point Rd. SE
Prior Lake, MN 55372-1714
Phone: (800) 998-1919
Fax: (800) 221-3248